



# DONAHUE INDUSTRIES, INC.

## A Full Service Metal Stamper

5 Industrial Drive, Shrewsbury, Massachusetts 01545 USA  
 Tel: (508) 845-6501 Fax: (508) 842-7665 E-mail: sales@donahueindustries.com

### Abrasive Wheel Insert Guide

Thin Wheel Inserts, Bushings, Diamond Inserts

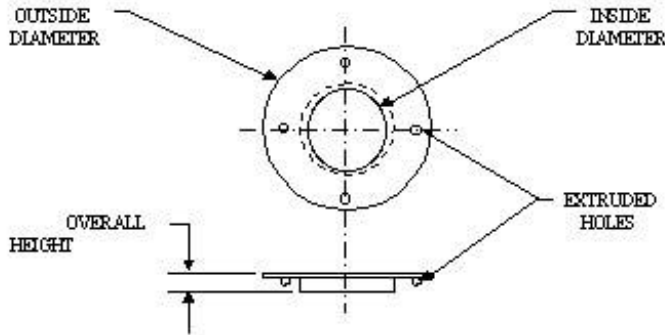

| Part No. | Inside Diameter | Outside Diameter | ID Overall Height | Donahue Drawing | Extr'd Holes<br>*Extra Hole |
|----------|-----------------|------------------|-------------------|-----------------|-----------------------------|
| H-1      | .382-.385"      | .750"            | .052-.062"        | H-SERIES        | 4                           |
| H-1NO    | .382-.385"      | .750"            | .052-.062"        | H-NO-SERIES     | 0                           |
| H-2      | .382-.385"      | .750"            | .110-.120"        | H-SERIES        | 4                           |
| H-2NO    | .382-.385"      | .750"            | .110-.120"        | H-NO-SERIES     | 0                           |
|          |                 |                  |                   |                 |                             |
| A-10-040 | .630-.633"      | 1.250"           | .030-.040"        | A-10-SERIES     | 4                           |
| A-10     | .630-.633"      | 1.250"           | .052-.062"        | A-10-SERIES     | 4                           |
|          |                 |                  |                   |                 |                             |
| A-13     | .630-.633"      | 1.250"           | .100-.115"        | A-13 THRU A-15  | 4                           |
| A-13-NO  | .630-.633"      | 1.250"           | .100-.115"        | A-13-NO         | 0                           |
| A-14     | .630-.633"      | 1.250"           | .165-.180"        | A-13 THRU A-15  | 4                           |
| A-15     | .630-.633"      | 1.250"           | .220-.240"        | A-13 THRU A-15  | 4                           |
|          |                 |                  |                   |                 |                             |
| A-2      | .630-.633"      | 1.500"           | .060-.070"        | A-2 SERIES      | 4                           |
| A-2C     | .630-.633"      | 1.500"           | .110-.120"        | A-2 SERIES      | 4                           |
| A-2CX    | .630-.633"      | 1.500"           | .110-.120"        | A-2 SERIES      | 4*                          |
| A-2CN    | .630-.633"      | 1.500"           | .130-.140"        | A-2 SERIES      | 4                           |

| Part No.         | Inside Diameter | Outside Diameter | ID Overall Height | Donahue Drawing | Extr'd Holes<br>*Extra Hole |
|------------------|-----------------|------------------|-------------------|-----------------|-----------------------------|
| A-3C             | .755-.758"      | 1.500"           | .110-.120"        | A-3 SERIES      | 4                           |
| M-1B (20MM)      | .792-.797"      | 2.000"           | .080-.095"        | M-SERIES        | 4                           |
| M-1 (20MM)       | .792-.797"      | 2.000"           | .105-.120"        | M-SERIES        | 4                           |
| MM-095<br>(20MM) | .797-.802"      | 2.000"           | .080-.095"        | MM-SERIES       | 4                           |
| MM-120<br>(20MM) | .797-.802"      | 2.000"           | .105-.120"        | MM-SERIES       | 4                           |
| BB-1             | .880-.882"      | 1.500"           | .105-.117"        | BB-1 & B-1S     | 4                           |
| B1-S             | .880-.882"      | 1.500"           | .147-.167"        | BB-1 & B-1S     | 4                           |
| BAU-1            | .881-.883"      | 1.125"           | .053-.063"        | BAU-SERIES      | 0                           |
| B-040            | .881-.883"      | 1.500"           | .030-.040"        | B-SERIES        | 4                           |
| BA-1             | .881-.883"      | 1.500"           | .053-.063"        | B-SERIES        | 4                           |
| BA-2             | .881-.883"      | 1.500"           | .060-.070"        | B-SERIES        | 4                           |
| B-5              | .881-.883"      | 1.500"           | .090-.100"        | B-SERIES        | 4                           |
| B-5NO            | .881-.883"      | 1.500"           | .090-.100"        | B-NO SERIES     | 0                           |
| B-1              | .881-.883"      | 1.500"           | .125-.145"        | B-SERIES        | 4                           |
| B-2              | .881-.883"      | 1.500"           | .168-.188"        | B-SERIES        | 4                           |
| B-3              | .881-.883"      | 1.500"           | .220-.250"        | B-SERIES        | 4                           |
| B-3NO            | .881-.883"      | 1.500"           | .220-.250"        | B-NO SERIES     | 0                           |
| B1-L             | .883-.885"      | 1.500"           | .125-.145"        | B1-L            | 4 TABS                      |

| Part No.  | Inside Diameter | Outside Diameter | ID Overall Height | Donahue Drawing | Extr'd Holes<br>*Extra Hole |
|-----------|-----------------|------------------|-------------------|-----------------|-----------------------------|
| C-060     | .886-.889"      | 1.500"           | .050-.060"        | C-060 SERIES    | 4                           |
| C-060-NO  | .886-.889"      | 1.500"           | .050-.060"        | C-060 SERIES    | 0                           |
| C-060-U   | .886-.889"      | 1.500"           | .050-.060"        | C-060 SERIES    | 4 W/STAR                    |
| C-100     | .886-.889"      | 1.500"           | .090-.100"        | C-SERIES        | 4                           |
| C-100-NO  | .886-.889"      | 1.500"           | .090-.100"        | C-NO SERIES     | 0                           |
| C-120     | .886-.889"      | 1.500"           | .105-.120"        | C-SERIES        | 4                           |
| C-120-NO  | .886-.889"      | 1.500"           | .105-.120"        | C-NO SERIES     | 0                           |
| C-145     | .886-.889"      | 1.500"           | .125-.145"        | C-SERIES        | 4                           |
| C-145-NO  | .886-.889"      | 1.500"           | .125-.145"        | C-NO SERIES     | 0                           |
| C-165     | .886-.889"      | 1.500"           | .150-.165"        | C-SERIES        | 4                           |
| C-165-NO  | .886-.889"      | 1.500"           | .150-.165"        | C-NO SERIES     | 0                           |
| C-250     | .886-.889"      | 1.500"           | .220-.250"        | C-SERIES        | 4                           |
| C-250-NO  | .886-.889"      | 1.500"           | .220-.250"        | C-NO SERIES     | 0                           |
| B-1NT     | .891-.894"      | 1.500"           | .090-.100"        | B-T SERIES      | 0                           |
| B-1T      | .891-.894"      | 1.500"           | .090-.100"        | B-T SERIES      | 4                           |
| A-5       | ** 1.008-1.011" | 2.000"           | .052-.062"        | A-5             | 4                           |
| A-6       | ** 1.008-1.011" | 2.000"           | .080-.095"        | A-6 THRU A-9    | 4                           |
| A-6B      | ** 1.008-1.011" | 2.000"           | .085-.105"        | A-6 THRU A-9    | 4                           |
| A-7       | ** 1.008-1.011" | 2.000"           | .115-.125"        | A-6 THRU A-9    | 4                           |
| A-8       | ** 1.008-1.011" | 2.000"           | .145-.160"        | A-6 THRU A-9    | 4                           |
| A-9       | ** 1.008-1.011" | 2.000"           | .175-.190"        | A-6 THRU A-9    | 4                           |
| AD-095    | ** 1.012-1.015" | 2.000"           | .080-.095"        | AD-SERIES       | 4                           |
| AD-095-NO | ** 1.012-1.015" | 2.000"           | .080-.095"        | AD-NO SERIES    | 0                           |
| AD-125    | ** 1.012-1.015" | 2.000"           | .110-.125"        | AD-SERIES       | 4                           |
| AD-125-NO | ** 1.012-1.015" | 2.000"           | .110-.125"        | AD-NO SERIES    | 0                           |
| AD-160    | ** 1.012-1.015" | 2.000"           | .145-.160"        | AD-SERIES       | 4                           |
| AD-160-NO | ** 1.012-1.015" | 2.000"           | .145-.160"        | AD-NO SERIES    | 0                           |

| Part No. | Inside Diameter | Outside Diameter | ID Overall Height | Donahue Drawing | Extr'd Holes<br>*Extra Hole |
|----------|-----------------|------------------|-------------------|-----------------|-----------------------------|
| AA-1     | ** 1.015-1.018" | 1.500"           | .143-.158"        | AA SERIES       | 0                           |
| AA-2     | ** 1.015-1.018" | 1.500"           | .198-.208"        | AA SERIES       | 0                           |

\*\* REDUCE 1" NOMINAL GRINDING WHEEL INSIDE DIAMETERS TO SMALLER ROUND ARBORS

|       |       |         |            |            |     |
|-------|-------|---------|------------|------------|-----|
| PRD-1 | .500" | 1" NOM. | .110-.125" | PRD-SERIES | N/A |
| PRD-2 | .625" | 1" NOM. | .110-.125" | PRD-SERIES | N/A |
| PRD-3 | .750" | 1" NOM. | .110-.125" | PRD-SERIES | N/A |
| PRD-4 | .875" | 1" NOM. | .110-.125" | PRD-SERIES | N/A |

|       |       |         |            |            |     |
|-------|-------|---------|------------|------------|-----|
| PRD-6 | 20 MM | 1" NOM. | .110-.125" | PRD-SERIES | N/A |
|-------|-------|---------|------------|------------|-----|

|     |              |        |            |          |   |
|-----|--------------|--------|------------|----------|---|
| J-1 | 1.258-1.261" | 2.000" | .052-.062" | J-SERIES | 4 |
| J-2 | 1.258-1.261" | 2.000" | .075-.085" | J-SERIES | 4 |
| J-3 | 1.258-1.261" | 2.000" | .110-.120" | J-SERIES | 4 |
| J-4 | 1.258-1.261" | 2.000" | .130-.145" | J-SERIES | 4 |

|     |              |        |            |          |   |
|-----|--------------|--------|------------|----------|---|
| K-1 | 1.508-1.511" | 3.000" | .085-.095" | K-SERIES | 4 |
| K-2 | 1.508-1.511" | 3.000" | .110-.120" | K-SERIES | 4 |
| K-3 | 1.508-1.511" | 3.000" | .140-.160" | K-SERIES | 4 |

|     |              |        |            |     |   |
|-----|--------------|--------|------------|-----|---|
| G-5 | 1.694-1.696" | 3.000" | .165-.180" | G-5 | 4 |
|-----|--------------|--------|------------|-----|---|

|     |              |        |            |          |   |
|-----|--------------|--------|------------|----------|---|
| G-4 | 1.760-1.766" | 3.000" | .128-.143" | G-SERIES | 4 |
| G-2 | 1.760-1.766" | 3.000" | .195-.210" | G-SERIES | 4 |
| G-3 | 1.760-1.766" | 3.000" | .245-.260" | G-SERIES | 4 |

|                     |              |        |            |          |   |
|---------------------|--------------|--------|------------|----------|---|
| L-090 (.021<br>THK) | 2.010-2.016" | 3.000" | .070-.090" | L-SERIES | 4 |
| L-260 (.021<br>THK) | 2.010-2.016" | 3.000" | .240-.260" | L-SERIES | 4 |

| Part No.         | Inside Diameter | Outside Diameter | ID Overall Height | Donahue Drawing | Extr'd Holes<br>*Extra Hole |
|------------------|-----------------|------------------|-------------------|-----------------|-----------------------------|
| N-140 (.021 THK) | 2.385-2.390"    | 3.000"           | .120-.140"        | N-SERIES        | 4                           |
| N-200 (.021 THK) | 2.385-2.390"    | 3.000"           | .180-.200"        | N-SERIES        | 4                           |

DIAMOND INSERTS FOR GRINDING WHEEL CENTERS

|                 | Diamond Size  | OD     |            |            |          |
|-----------------|---------------|--------|------------|------------|----------|
| E-1DS(.012 THK) | 1.286 x .829" | 1.875" | .080-.095" | E-1D SPEC  | 4        |
| E-2             | 1.235 x .827" | 2.000" | .080-.095" | E-SERIES   | 4        |
| E-2N            | 1.235 x .827" | 2.000" | .080-.095" | E-2N       | 4 W/STAR |
| E-3             | 1.235 x .827" | 2.000" | .110-.120" | E-SERIES   | 4        |
| E-6V            | 1.255 x .825" | 2.000" | .110-.120" | E6V & E6VX | 4        |
| E-6VX*          | *W/.125 HOLE  | "      | "          | "          | 4*       |

STEEL: REDUCE DIAMOND GRINDING WHEEL CENTERS TO SMALLER ROUND ARBORS

|       | Diamond Size  | Arbor ID |            |           |     |
|-------|---------------|----------|------------|-----------|-----|
| SE-2  | 1.220 x .840" | .633"    | .105-.120" | SE-SERIES | N/A |
| SE-2A | 1.220 x .840" | .644"    | .105-.120" | SE-SERIES | N/A |

PLASTIC: REDUCE DIAMOND GRINDING WHEEL CTRS. TO SMALLER ROUND ARBORS

|      | Diamond Size  | Arbor ID |       |           |     |
|------|---------------|----------|-------|-----------|-----|
| PE-1 | 1.200 x .821" | .505"    | .090" | PE-SERIES | N/A |
| PE-2 | 1.200 x .821" | .630"    | .090" | PE-SERIES | N/A |